



# LP/LM800 SOLARIS Series

Warning lights



# LP/LM800 SOLARIS Series

New **LP/LM800 SOLARIS** warning lights, with Solaris LED reflector technology of **Federal Signal Vama** provide excellent results as priority lights on emergency and undercover vehicles. It can be installed either permanently (LP models) and temporarily using strong magnets and suction cups (LM model). Other features are:



**360° LIGHT BEAM DISTRIBUTION.** Solaris technology and its special spreader lens maximizes light beam distribution through 360° around vehicle, avoiding dark spots.



**EVERY NEED SOLUTIONS.** Beacon lights with 1 or 2 levels of 15 Solaris LED rings with blue, amber or red lights, permanent mount for emergency vehicles, or magnetic mount for undercover ones, etc.



**HIGH STRENGTH HOUSING.** Durable shockproof polycarbonate lens with reinforced polyamide base. With IP protection IPX9K.



**SYNCRONIZABLE.** LP800 Series could be synchronized with other Federal Signal Vama vehicle priority lights (LP400).

## Approvals

Blue, amber lights satisfy R65 European Directive.

All models satisfy Electromagnetic Compatibility Directive 2004/104.

With IP protection IPX9K.



## Available colours:



LP/LM800 suitable for different vehicle applications.





High intensity

Low amp draw

Easy installation

Several flash patterns

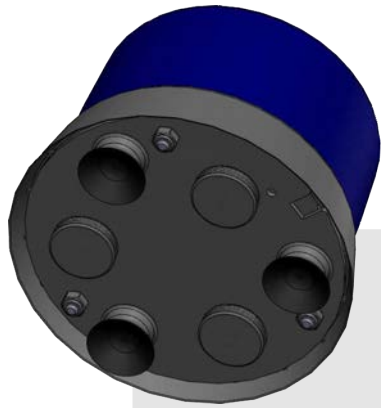
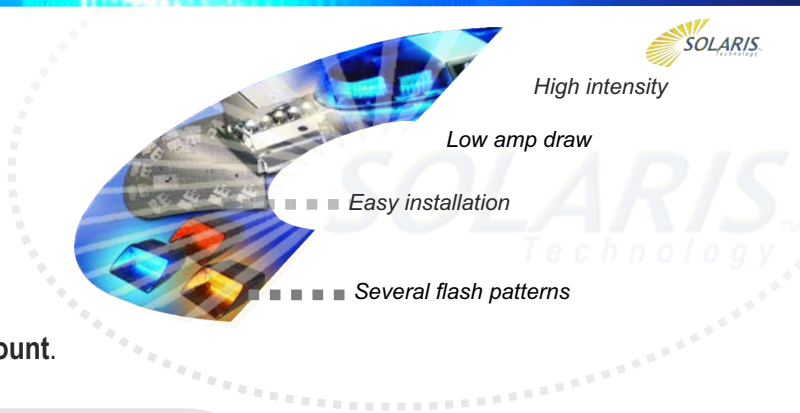

### LM800

Priority light with magnetic mount.

Magnetic mount model **LM800** has got a **cigarette plug** power connection for quick use on emergency situations.

Incorporates 3 magnets with anti-scratch silicone and 3 suction cups for a perfect grip and stability.

### LP800

Priority light with permanent mount.

The base has 3 screws and 3 nuts that secure the lights permanently to the vehicle.  
(Design B1 as defined by DIN 14620).

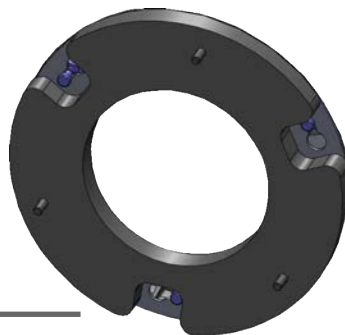
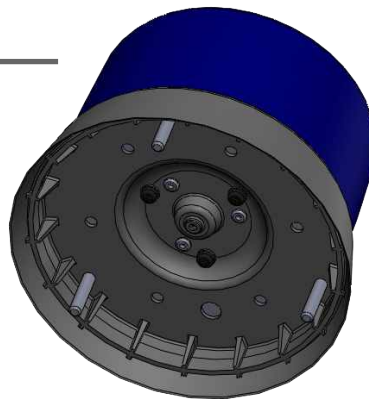

### BD-LP800 base DIN for LP800.

The DIN mounting kit option includes all the elements necessary to fit it to the standard LP800 and has been designed especially to facilitate the incorporation of LP800 in the assembly lines. This mounting allows the placement of the lights from the outside, which makes both installation and successive maintenance easier. This base incorporates a safety system that ensures proper securing of the assembly.

Impact resistant, anti-vibration and durable shockproof **polycarbonate lens**.



Reinforced **polyamide base** (included).

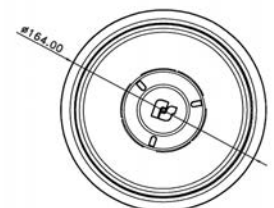
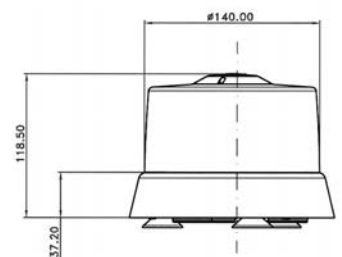

Technical specifications	LM800	LP800	LP800 (base DIN)
Electrical power:	12-24V	12-24V	12-24V
Operating temperature:	-20°C to +50°C	-20°C to +50°C	-20°C to +50°C
Current draw (average):	1 A (blue and red) 0,6 A (amber)	1 A (blue and red) 0,6 A (amber)	1 A (blue and red) 0,6 A (amber)
LED colours:	Blue, red and amber	Blue, red and amber	Blue, red and amber
Lens colours:	Blue, amber or red	Blue, amber, red or clear	Blue, amber, red or clear
Dimensions:	140 mm (diam - dome) 164 mm (diam - base) 120 mm (height)	140 mm (diam - dome) 164 mm (diam - base) 95 mm (height)	140 mm (diam - dome) 164 mm (diam - base) 109 mm (height)
Weight:	1200 g (1 level) 1300 g (2 level)	590 g (1 level) 700 g (2 level)	590 gr (1 level) + 270 gr 700 gr (2 levels) + 270 gr

## HOW TO ORDER

Choose reference from below:

### LM800 Solaris - Magnet mounting (\*)

- R65** 2003039 (1) level, (2) flash patterns, light amber, amber lens, magnetic mount and cigarette lighter plug, dual voltage. R65 Class 1 (flash mode) approved.
- R65** 2003040 (1) level, (2) flash patterns, blue light, blue lens, magnetic mount and cigarette lighter plug, dual voltage. R65 Class 1 (flash mode) approved.
- 2003041 (1) level, (2) flash patterns, red light, red lens, magnetic mount and cigarette lighter plug, dual voltage.
- R65** 2003043 (2) levels, (2) flash patterns, light amber, amber lens, day / night, magnetic mount and cigarette lighter plug, dual voltage. R65 Class 2 (flash mode) approved.
- R65** 2003044 (2) levels, (2) flash patterns, blue light, blue lens, day / night, magnetic mounting and cigarette lighter plug, dual voltage. R65 Class 2 (flash mode) approved.
- R65** 2003042 (2) levels, (2) flash patterns, red light, red lens, magnetic mount and cigarette lighter plug, dual voltage. R65 Class 1 (flash mode) approved.

(\*) Maximum speed for magnetic mount model on the roof of the vehicle to 200km / h.

(\*\*) Magnetic mounting models produced for a temporary use on the roof of the vehicle.

### LP800 Solaris - Permanent mount

- R65** 2003034 (1) level, (8) flash patterns, light amber, amber lens, day / night and cruise light, permanent mount, dual voltage. R65 Class 1 (flash mode) approved.
- R65** 2003026 (1) level, (8) flash patterns, blue light, blue lens, day / night and cruise light, permanent mount, dual voltage. R65 Class 1 (flash mode) approved.
- 2003035 (1) level, (8) flash patterns, red light, red lens, day / night and cruise light, permanent mount, dual voltage.
- R65** 2003036 (2) levels, (8) flash patterns, light amber, amber lens, day / night and cruise light, permanent mount, dual voltage. R65 Class 2 (flash mode) approved.
- 2003038 (2) levels, blue light-amber, clear lens, permanent mount, dual voltage. R65 Class 1 (flash mode) approved.
- R65** 2003027 (2) levels, (8) flash patterns, blue light, blue lens, day / night and cruise light, permanent mount, dual voltage. R65 Class 2 (flash mode) and Class 1 (rotative mode) approved.
- R65** 2003037 (2) levels, (8) flash patterns, red light, red lens, day / night and cruise light, permanent mount, dual voltage. R65 Class 2 (flash mode) and Class 1 (rotative mode) approved.

### LP800 Solaris Base DIN

8232795 BD-LP800 DIN Base for LP800



**FEDERAL SIGNAL VAMA**

Protecting people and our planet

Dr. Ferrán, 7 - 08339 Vilassar de Dalt - Barcelona - Spain  
phone 0034 93 741 79 00 - Email:marketing@vama.es

[www.fedsigvama.com](http://www.fedsigvama.com)

