

TECHNICAL SPECIFICATIONS

Geminis standard version

Voltage	Multi-voltage (10 - 30V)			
Operating temperature	- 30 to + 60 °C			
Consumption	12V		24V	
	Maximum	Average	Maximum	Average
Blue	5,2A	1,7A	3,4A	1,2A
Amber	5,2A	1,7A	3,4A	1,2A
Red	4,4A	1,5A	2,5A	0,8A
Cruise mode consumption	0,3 A (12V and 24V)			
Colours of LEDs	Blue, red, amber			
Colour of lenses	Clear			
Dimensions	Permanent: 168 mm x 129 mm			
	Magnetic: 147 mm x 118 mm			
Weight	Permanent : 1.011 g			
	Magnetic: 1.210 g			
Mount	Permanent DIN / Magnetic			
N° de Flash Patterns	(QUAD R65 y S-A R65)			
Flash frequency	2 Hz			
Flash rate (per/min)	120			

Geminis-B with rechargeable battery

Voltage	12V	
Operating temperature	- 20 to + 50 °C	
Consumption	12V	
	Maximum	Average
Blue	2,6A	1,0A
Amber	2,6A	1,0A
Charging consumption	2,0A	
Maintenance consumption	0,05A	
Colours of LEDs	Blue, amber	
Colour of lenses	Clear	
Dimensions	147 mm x 118 mm	
Weight	Light : 1.007 gr	
	Cable: 163,5 gr	
Mount	Magnetic	
N° de Flash Patterns	2 (QUAD R65 & S-A R65)	
Flash frequency	2 Hz	
Flash rate (per/min)	120	
Operation time/charging	180/90 minutes	



In process

In process

HOW TO ORDER

Select the options from the following list:

GEMINIS STANDARD

Magnetic mounting(*)

- 2002409 Warning light, (1) level, (2) flash patterns, blue light, clear lens, magnetic mount and cigarette lighter plug, multi voltage. R65 Class 2 (flash mode) approved.
- 2002411 Warning light, (1) level, (2) flash patterns, red light, clear lens, magnetic mount and cigarette lighter plug, multi voltage. R65 Class 2 (flash mode) approved.
- 2002410 Warning light, (1) level, (2) flash patterns, amber light, clear lens, magnetic mount and cigarette lighter plug, multi voltage. R65 Class 2 (flash mode) approved.
- 2002412 BICOLOUR Warning light, (1) level, (2) flash patterns, blue-red light, clear lens, magnetic mount and cigarette lighter plug, multi voltage. R65 Class 2 (flash mode) approved.
- 2002403 BICOLOUR Warning light, (1) level, (2) flash patterns, blue-amber light, clear lens, magnetic mount and cigarette lighter plug, multi voltage. R65 Class 2 (flash mode) approved.
- 2002413 BICOLOUR Warning light, (1) level, (2) flash patterns, amber-red light, clear lens, magnetic mount and cigarette lighter plug, multi voltage. R65 Class 2 (flash mode) approved.

(*) Maximum speed for this model on the roof of the vehicle 250 km/h.

Magnetic mounting models are produced for a temporary use on the roof of the vehicle.

DIN Permanent mounting

- 2002405 Warning light, (1) level, (2) flash patterns, blue light, clear lens, DIN permanent mount, multi voltage. R65 Class 2 (flash mode) approved.
- 2002407 Warning light, (1) level, (2) flash patterns, red light, clear lens, DIN permanent mount, multi voltage. R65 Class 2 (flash mode) approved.
- 2002406 Warning light, (1) level, (2) flash patterns, amber light, clear lens, DIN permanent mount, multi voltage. R65 Class 2 (flash mode) approved.
- 2002404 BICOLOUR Warning light, (1) level, (2) flash patterns, blue-red light, clear lens, DIN permanent mount, multi voltage. R65 Class 2 (flash mode) approved.
- 2002402 BICOLOUR Warning light, (1) level, (2) flash patterns, blue-amber light, clear lens, DIN permanent mount, multi voltage. R65 Class 2 (flash mode) approved.
- 2002408 BICOLOUR Warning light, (1) level, (2) flash patterns, amber-red light, clear lens, DIN permanent mount, multi voltage. R65 Class 2 (flash mode) approved.

DIN Permanent mounting accessory

- 8299997 Connector Kit for permanent mount.

GEMINIS-B, MAGNETIC MOUNT AND WITH RECHARGEABLE BATTERY

- 2002414 Warning light LEDs, (1) level, (2) flash patterns, blue light, clear lens, rechargeable battery, magnetic mount and cigarette lighter plug, 12V. Not Homologated UN R65*
- 2002415 Warning light LEDs, (1) level, (2) flash patterns, blue-amber light, clear lens, rechargeable battery, magnetic mount and cigarette lighter plug, 12V. Not Homologated UN R65*

* The European regulation R65 does not allow to approve devices with power through rechargeable batteries, it is only allowed to approve devices with continuous power.

Contact our Commercial Department for further information.

www.fedsigvama.com

FEDERAL SIGNAL VAMA
Protecting people and our planet

GEMINIS Series

Priority warning lights



FEDERAL SIGNAL VAMA
Protecting people and our planet

ISO 9001:2008 Certified Company
Dr. Ferrán, 7
08339 VILASSAR DE DALT
BARCELONA - SPAIN
Phone 34 93 741 79 00
Email: marketing@vama.es

GEMINIS Series

Federal Signal Vama presents the dual colour warning light Geminis Series, a single and dual colour omnidirectional LEDs priority light.

Geminis standard single colour and dual colour version allows combining 2 colours between blue, red and amber. Furthermore, this model can be chosen with permanent fixation DIN or magnetic mounting. According to R65 European Regulation Class 2.

GEMINIS-B incorporates a rechargeable battery, and it is available in single colour and dual colour (blue/amber) with magnetic mounting.

All models according to with IPX6 (*) and IPX9 (*) dust and water protection grades.

Model	Tension	Mount	Homologations	day/night function	Dust / water Protection
STANDARD VERSION	10-30V	Permanent and Magnetic	R65 Class 2/R10	YES	IPX6, IPX9
BATTERY VERSION	12V	Magnetic	R10	NO	IPX6(*), IPX9 (*)

(*) in process

SINGLE COLOUR AND DUAL COLOUR PRIORITY LIGHTS









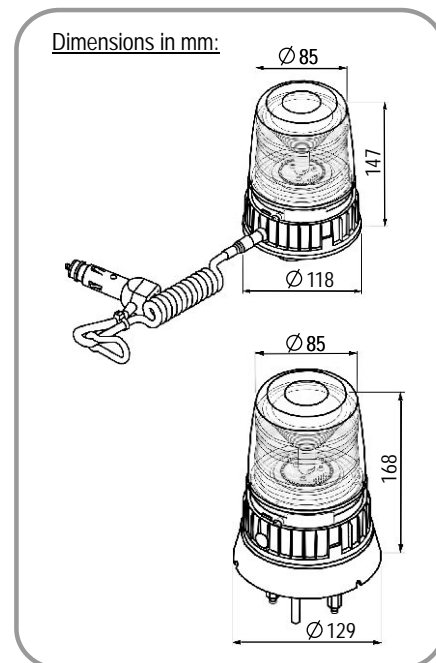
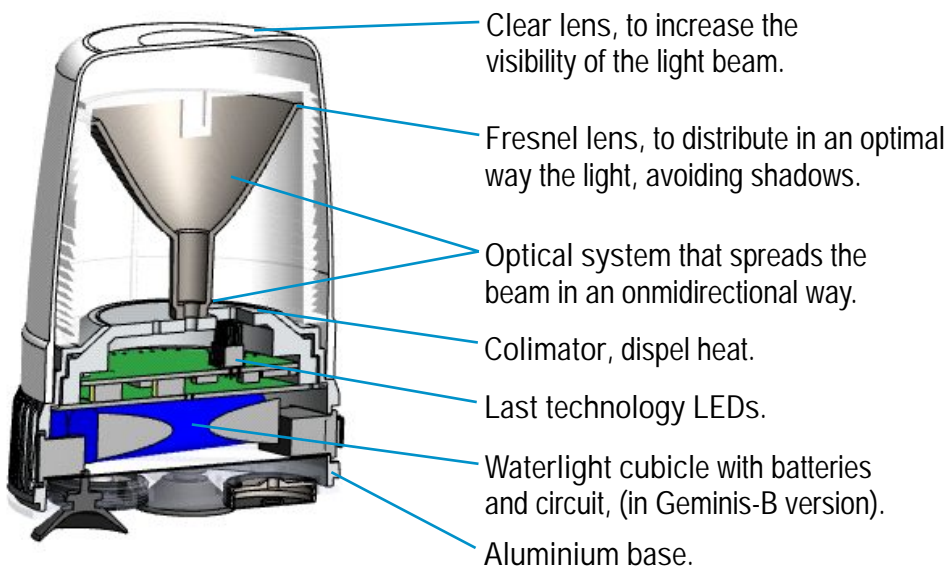

2 MOUNTING OPTIONS



GEMINIS STRUCTURE





-  **DUAL COLOUR TECHNOLOGY:** Thanks to this advanced product range and its improved bicolour technology, the priority light Geminis allows to combine 2 colours from: blue - amber, blue - red and red-amber.
-  **VERY COMPACT AND LIGHT:** To guarantee its usage in an unexpected emergency situation, the magnetic version can be operated within one hand only, allowing a fast and simple setting.
-  **360° LIGHT DISTRIBUTION:** The applied technology and the special lens impression enables to maximize the beam light distribution in 360° around the vehicle, avoiding dark spots and shadows.
-  **PHOTOCELL SENSOR:** For standard version, due to the photocell sensor included inside the Geminis magnetic version, the day/night function is changed automatically. This allows to be permanently adapted to lighting conditions.
-  **SYNCHRONIZABLE:** For standard version, Geminis series allows the synchronization with other warning lights of the same product range.
-  **HIGH RESISTANCE:** Polycarbonate and impact-resistant lens.
-  **PROTECTION AGAINST DUST AND WATER:** Geminis Series according with IPX6 and IPX9 dust and water protection grades.
-  **THERMAL PROTECTION:** To avoid the overheating of the light due to high sun exposures, they include a thermal protection, a need in areas where the lights are exposed to extreme warm environments.
-  **WITH BATTERY:** Magnetic mounting and battery version available.



MANIPULATION IS POSSIBLE WITH ONLY ONE HAND!

In case of an unexpected emergency situation, thanks to its reduced dimensions, Geminis light allows a fast and simple setting.

HOW TO CHANGE...		
	THE FLASH PATTERN	DAY / NIGHT FUNCTION
MAGNETIC MOUNTING	 Magnetic sensor	 Automatic photocell
DIN PERMANENT MOUNTING	Switches	Switches

Possibility to add a waterproof connector in Geminis series DIN permanent mounting, to make a very easy replacement of the light. (The connector is sold separately).